



- High Accuracy
- Broad Bandwidth
- Low Zero-drift

Shenzhen Hangzhi Precision Electronics Co. Ltd.

## AIT500-SG High-Precision Current Transducer

AIT500-SG has a high gain and measurement accuracy in the full bandwidth range, due to the application of the multi-point zero-flux technology system and high-frequency ripple sensing channel on top of currently existing DC sensor technology.

The multi-point zero-flux technology system secures the high accuracy by utilizing the technology combination of exciting magnetic flux closed-loop control, self-excited magnetic flux gate and multi-closed-loop control that realizes the closed-loop control between excitation magnetic flux and AC/DC magnetic flux generated by primary current, while the high-frequency ripple sensing channel allows the sensor to have the high performance over the full bandwidth range.

### Product photo





- High Accuracy
- Broad Bandwidth
- Low Zero-drift

Shenzhen Hangzhi Precision Electronics Co. Ltd.

## Key Technologies

- ◇ Excitation closed-loop control technology
- ◇ Self-excitation demagnetization technology
- ◇ Multi-point zero-flux technology
- ◇ Temperature control compensation technology
- ◇ Multi-range automatic switching technology

## Features

- ◇ Insulated measurement between primary and secondary side
- ◇ Excellent linearity and accuracy
- ◇ Extremely low temperature drift
- ◇ Extremely low zero drift
- ◇ Broad band and low response time
- ◇ Strong anti-electromagnetic interference

## Application Domain

- ◇ Medical Equipment: Scanner, MRI
- ◇ Power industry: Converter, Inverter
- ◇ Renewable Energy: Photovoltaic, Wind energy
- ◇ Testing Instrument: Power analyzer, High-precision power supply
- ◇ Smart Power Grid: Power generation and battery monitoring, Medium low voltage substation
- ◇ Industry Control: Industrial motor drive, UPS, Welding, Robot, Hoist, Elevator, Ski lift
- ◇ Rail Transit: EMU, Metro, Trolley car
- ◇ Ship: Electric driven ship
- ◇ Car: Electric car

## Electrical Performance

| Parameter                            | Symbol       | Measuring Conditions  | Min    | Typ    | Max    | Unit |
|--------------------------------------|--------------|-----------------------|--------|--------|--------|------|
| Primary nominal direct current       | $I_{PN\_DC}$ | —                     | —      | ±500   | —      | Adc  |
| Primary nominal alternating current* | $I_{PN}$     | —                     | —      | 353    | —      | Aac  |
| Primary overload current             | $I_{PM}$     | 1 Minute              | —      | —      | ±600   | Adc  |
| Operating Voltage                    | $V_C$        | —                     | ±14.2  | ±15    | ±15.8  | V    |
| Power consumption current            | $I_{PWR}$    | Rated primary current | ±30    | ±363   | ±433   | mA   |
| Current ratio                        | $K_N$        | Input : Output        | 1500:1 | 1500:1 | 1500:1 | —    |
| Rated output current                 | $I_{SN}$     | Rated Primary current | —      | ±0.333 | —      | A    |
| Secondary burden resistance          | $R_M$        | See Fig. 1            | 0      | 3      | 10     | Ω    |

\* refers to AC effective value



- High Accuracy
- Broad Bandwidth
- Low Zero-drift

Shenzhen Hangzhi Precision Electronics Co. Ltd.

## Accuracy Measurement

| Parameter                  | Symbol       | Measuring Conditions                                    | Min | Typ | Max                                  | Unit             |
|----------------------------|--------------|---|-----|-----|--------------------------------------|------------------|
| Accuracy                   | $X_G$        | Input direct current, $25\pm 10^\circ\text{C}$          | —   | —   | 10                                   | ppm              |
| Linearity                  | $\epsilon_L$ | —   | —   | —   | 2                                    | ppm              |
| Temperature stability      | $T_C$        | —   | —   | —   | 0.1                                  | ppm/K            |
| Time stability             | $T_T$        | —   | —   | —   | 0.2                                  | ppm/month        |
| Power supply interference  | $T_V$        | —   | —   | —   | 1                                    | ppm/V            |
| Zero offset current        | $I_0$        | @ $25^\circ\text{C}$                                    | —   | —   | 1 (can be adjusted to zero by users) | ppm              |
| Ripple current             | $I_N$        | DC-10Hz   | —   | —   | 0.5                                  | ppm              |
| Dynamic response time      | $t_r$        | $di/dt=100\text{A}/\mu\text{s}$ , rised to 90% $I_{PN}$ | —   | —   | 1                                    | $\mu\text{s}$    |
| Current change rate        | $di/dt$      | —   | 100 | —   | —                                    | A/ $\mu\text{s}$ |
| Frequency bandwidth (-3dB) | F            | —   | 0   | —   | 500                                  | kHz              |
| Zero offset current        | $I_{OT}$     | Full temperature range                                  | —   | —   | $\pm 5$                              | $\mu\text{A}$    |

## Safety Characteristics

| Parameter   | Symbol | Measuring Conditions | Value | Unit |
|---|--------|----------------------|-------|------|
| Insulation voltage / Between primary and secondary sides                    | Vd     | 50Hz, 1min           | 5     | KV   |
| Transient isolation withstand voltage / Between primary and secondary sides | Vw     | 50 $\mu\text{s}$     | 10    | KV   |
| Creepage distance / Between the primary and the outer shell                 | dCp    | —                    | 11    | mm   |
| Clearance distance / Between the primary and the outer shell                | dCi    | —                    | 11    | mm   |
| Comparative tracking index  | CTI    | IEC-60112            | 600   | V    |

## General Characteristics

| Parameter                     | Symbol | Measuring Conditions | Min | Typ           | Max | Unit             |
|-------------------------------|--------|----------------------|-----|---------------|-----|------------------|
| Ambient operating temperature | $T_A$  | —                    | -40 | —             | +85 | $^\circ\text{C}$ |
| Mass                          | M      | —                    | —   | 1060 $\pm 20$ | —   | g                |



- High Accuracy
- Broad Bandwidth
- Low Zero-drift

Shenzhen Hangzhi Precision Electronics Co. Ltd.

## Burden Resistor Instructions

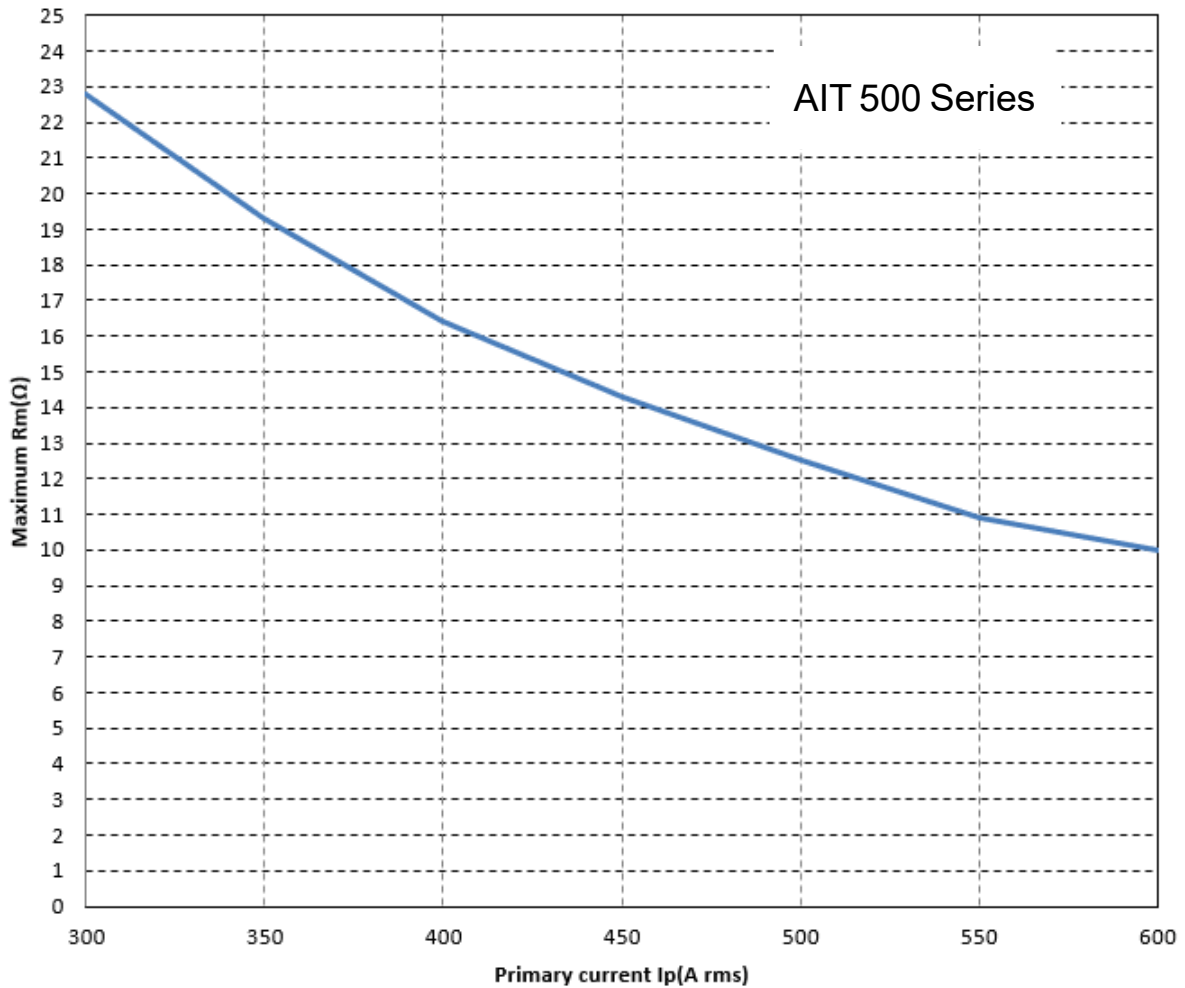

## Operating Status Instructions

### ◇ Normal status:

The green indicator is on when the device is running normally:

After the device is powered on, the green indicator is on when the device is running normally, and the 3rd pin and 8th pin of D-Sub9 interface are connected together.

### ◇ Fault status:

The green light will be off when the transducer is in fault mode.

Trouble-shooting:

- When the green light is off, the power supply should be checked as the first step;
- If the power supply is normal, then the primary current is over the specified measurement range and the transducers will be in overload mode.

In this mode, the transducers will be working in non-zero flux mode, that the secondary current remains at specified maximum output, the secondary and primary currents are not in proportional and the connection between pin 3 & 8 of the DB9 interface will be off.

**SHENZHEN HANGZHI PRECISION ELECTRONICS CO. LTD**

Add: Rm 531, Building B, Huayuan Hi-Tech Innovation Park,  
Baoyuan Road, Bao'an District, Shenzhen, China P.R.

Email: sales@hangzhicn.com Technical support: info@hangzhicn.com  
Tel: +86(0)755-8259 3440 Website: www.hangzhicn.com



- High Accuracy
- Broad Bandwidth
- Low Zero-drift

Shenzhen Hangzhi Precision Electronics Co. Ltd.

## Connection system

### 1. D-Sub9 Connection terminal pin function definition

| Pin No.    | 1               | 2、7 | 3            | 4   | 5              | 6        | 8            | 9              |
|------------|-----------------|-----|--------------|-----|----------------|----------|--------------|----------------|
| Definition | I_Output<br>COM | N.C | Interlock(-) | GND | -15V<br>Supply | I_Output | Interlock(+) | +15V<br>Supply |

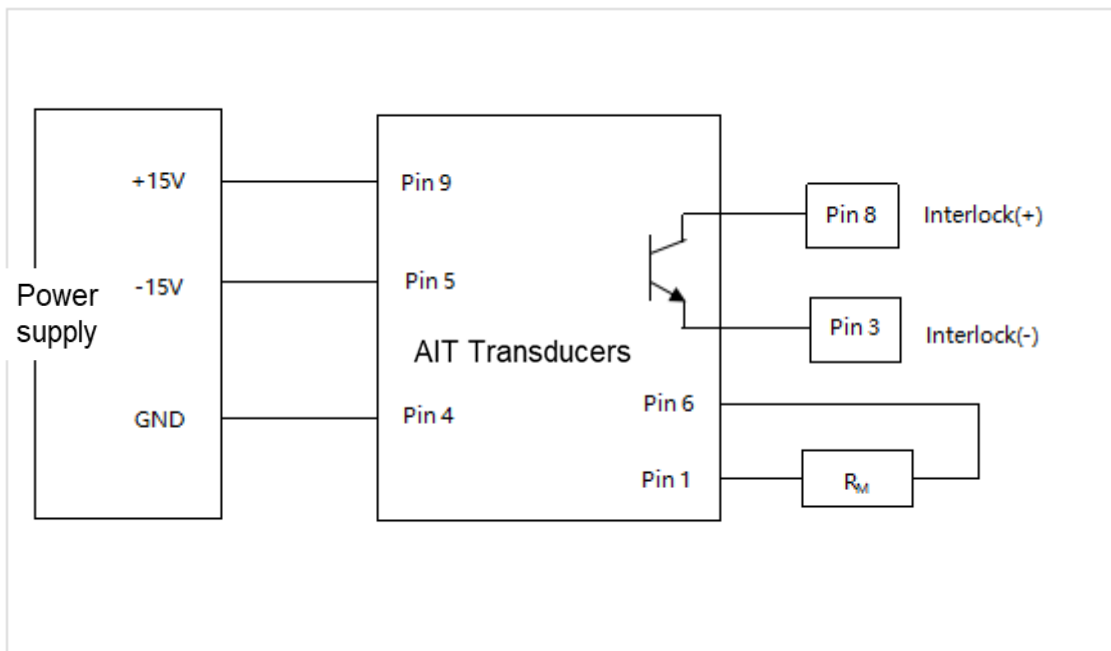

Test instruction:

The primary current  $I_P$  can be obtained by measuring the test current  $I_S$  flowing through  $R_M$  or the voltage  $U_R$  across  $R_M$ :

$$I_P = K_N * I_S = K_N * (U_R/R_M)$$

### 2. Interlock Port connection description:

There are two types of Interlock Port connection based on users' actual application shown as Fig A and Fig B:



- High Accuracy
- Broad Bandwidth
- Low Zero-drift

Shenzhen Hangzhi Precision Electronics Co. Ltd.

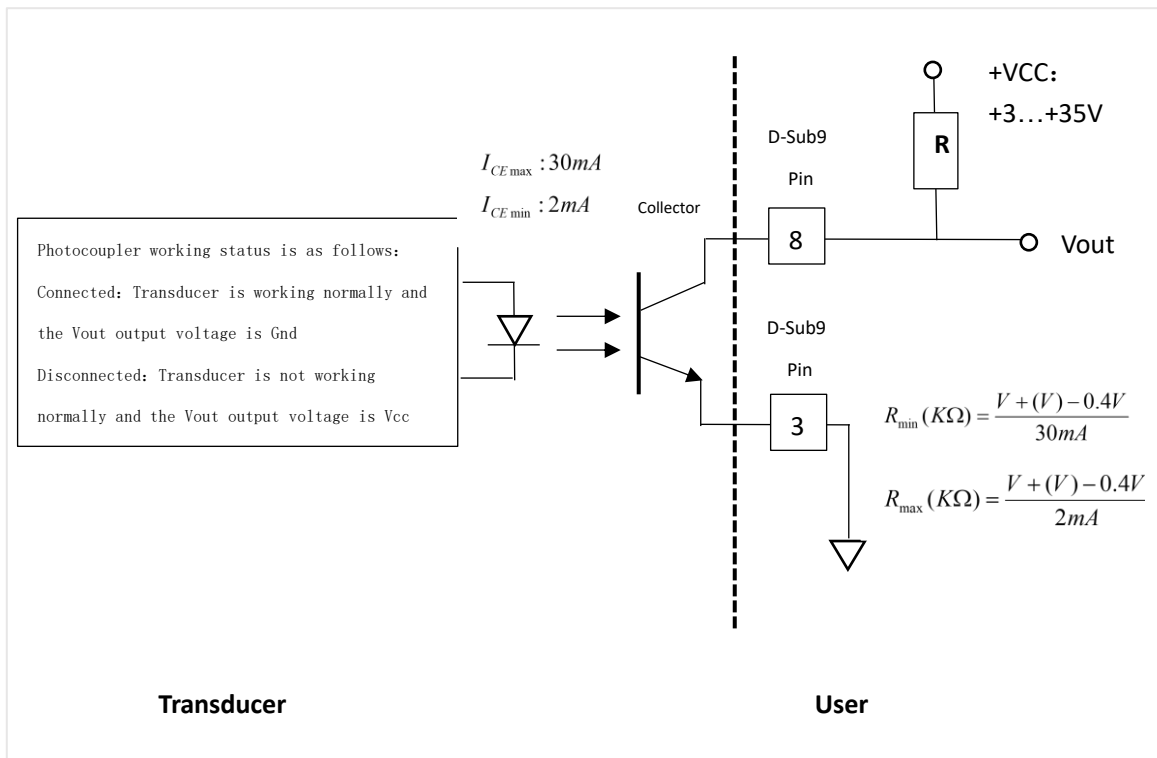

Fig A: Low level output when the transducer is operating normally

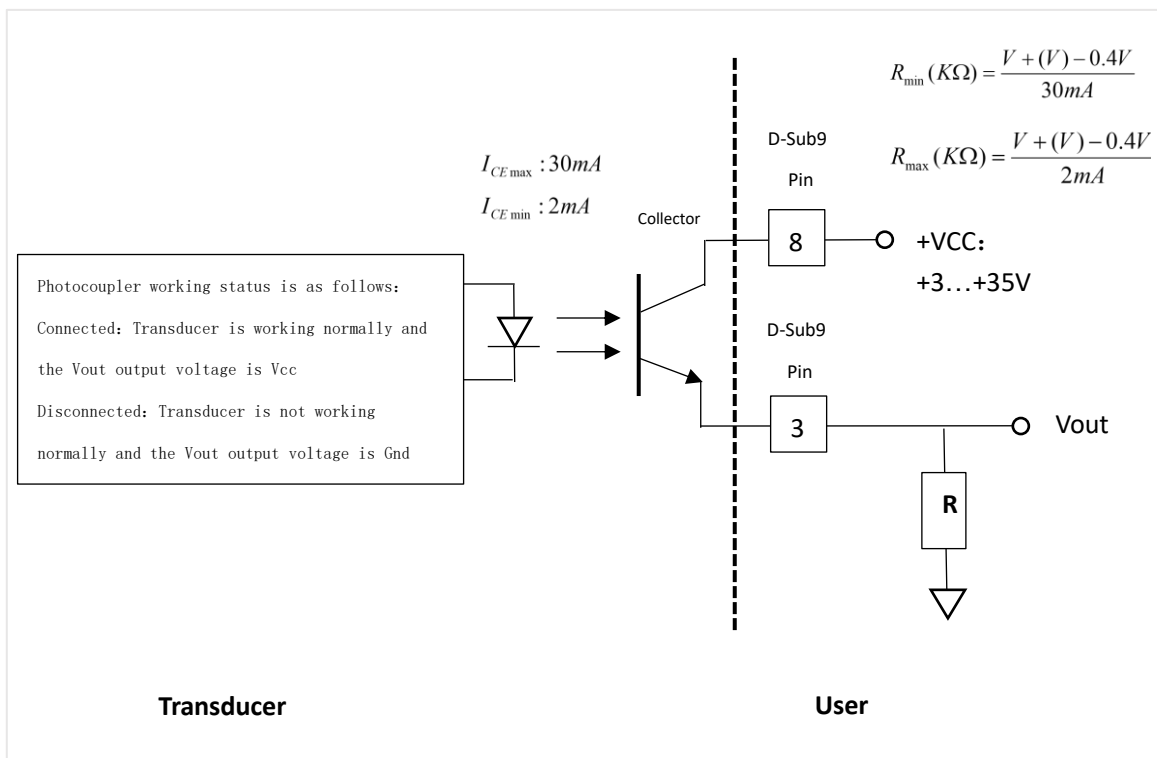

Fig B: High output when the transducer is operating normally



- High Accuracy
- Broad Bandwidth
- Low Zero-drift

Shenzhen Hangzhi Precision Electronics Co. Ltd.

3. The output of the pin Vout in the optocoupler is related to the user-designed circuit, as shown in the following table.

| Parameter | Vout  | Description   |
|-----------|-------|---|
| Fig A     | <0.2V | The transducer is working normally.   |
|           | Vcc   | The transducer is working abnormally, i.e., in overload mode or abnormal power supply |
| Fig B     | <0.2V | The transducer is working abnormally, i.e., in overload mode or abnormal power supply |
|           | Vcc   | The transducer is working normally.   |

## Dimensions

Unit: mm

